

1. J355HA M30-P1 BOLLARD



Please read with the utmost care this manual supplied with the product, since it contains important indications about safety, installation, use and maintenance.

1.1 GENERAL NOTES

These instructions apply to model

J355HA M30-P1

This model refers to anti-terrorist automatic hydraulic traffic bollards. The cylinder is driven by a two-motor hydraulic unit fixed inside the structure.

1.2 DESCRIPTION AND TECHNICAL SPECIFICATIONS

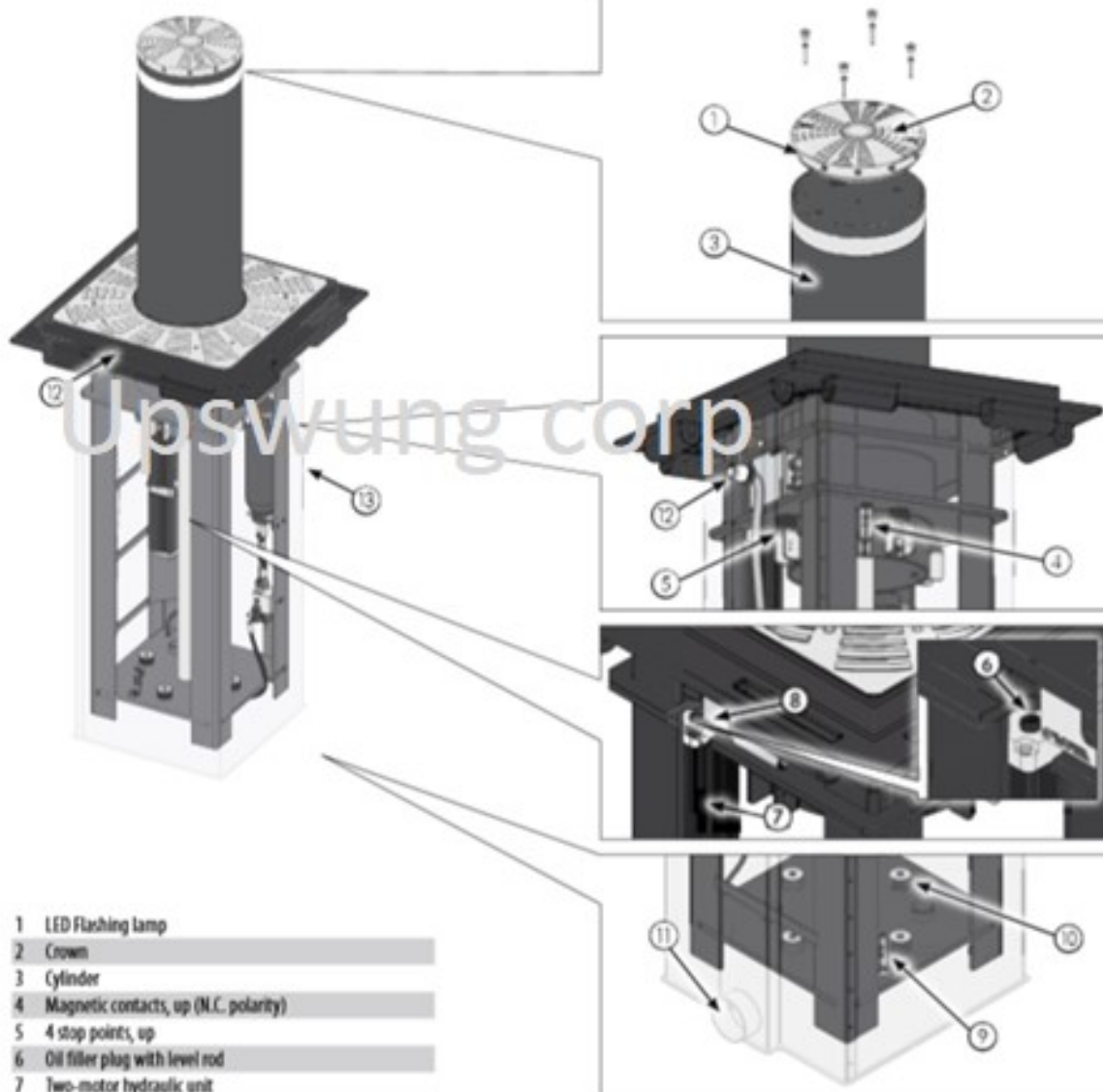

- 1 LED Flashing lamp
- 2 Crown
- 3 Cylinder
- 4 Magnetic contacts, up (N.C. polarity)
- 5 4 stop points, up
- 6 Oil filler plug with level rod
- 7 Two-motor hydraulic unit
- 8 Junction box
- 9 Magnetic contact, down (N.C. polarity)
- 10 4 stop points, down
- 11 Ø 100 mm hole for draining or pump connection
- 12 Cable routing hole
- 13 Foundation pit

Tab.A - Technical specifications

MODEL	J35SHA M30-P1
Power supply	230 V~ (+6% -10%) 50 (60) Hz
Max. absorbed power (W)	2800
Max. force (N)	5000
Max. pump delivery (lpm)	6
Minimum lifting time (sec)	6
Minimum lifting time (using EFO) (sec)	1,5
Minimum lowering time (sec)	2
Operating ambient temperature (°C)	-15 + +55
Weight bollard and pit (kg)	490 (bollard) 250 (pit)
Oil quantity (l) (1)	3
Protection class	IP66
Overall dimensions	See Fig.2
Capacitor (2)	2 x 20µf - 400V
Burglar-proofing (l) (3)	656000



(1) check the oil level using the rod attached to the filler plug (Fig. 1 ref. 3) with the piston rod completely retracted and pressurised EFO system.

(2) The two thrust capacitors (20µf - 400v) can be pre-loaded inside the junction box (see Fig. 13).

(3) certified under ASTM F2656-07 CLASS M30-P1



1.3 DIMENSIONS

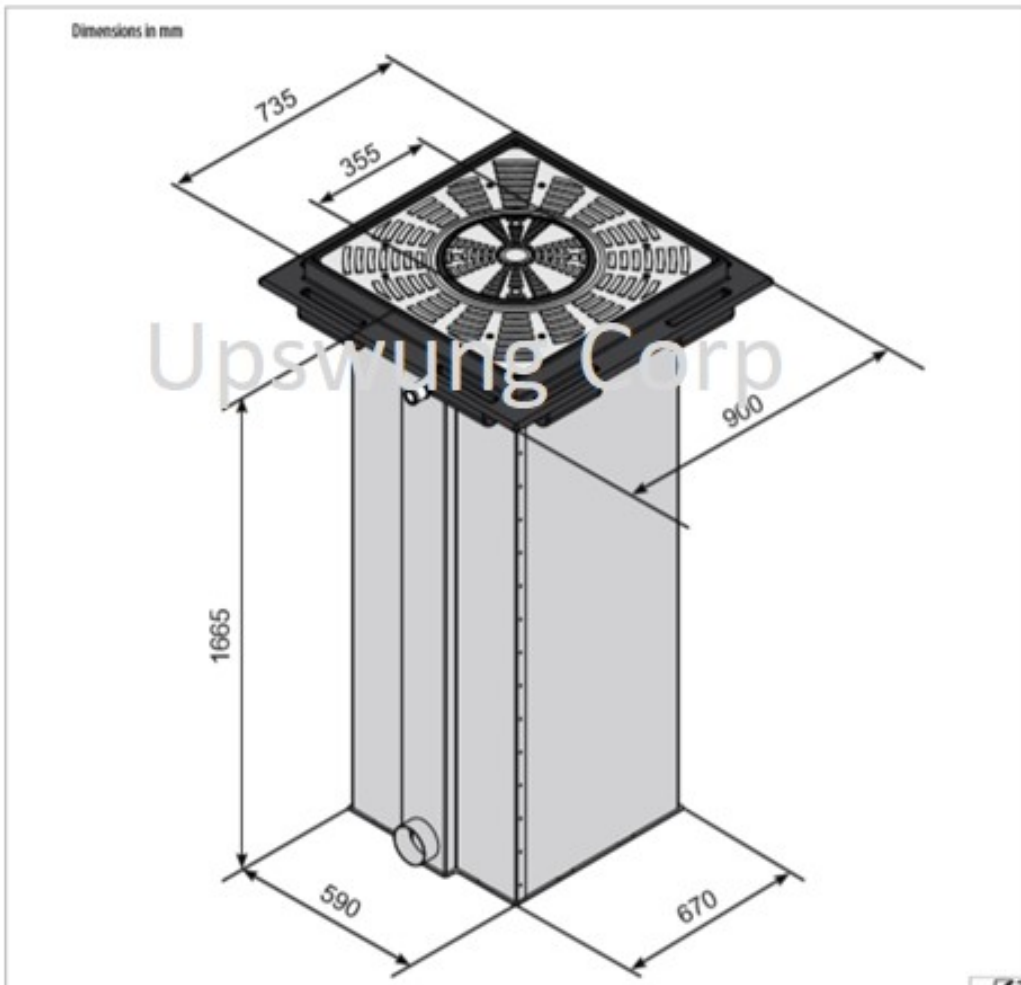

1 Tab.A - Technical specifications

MODEL	J355HA M30-P1
Power supply	230 V~ (+6% -10%) 50 (60) Hz
Max. absorbed power (W)	2800
Max. force (N)	5000
Max. pump delivery (lpm)	6
Minimum lifting time (sec)	6
Minimum lifting time (using EFO) (sec)	1,5
Minimum lowering time (sec)	2
Operating ambient temperature (°C)	-15 ÷ +55
Weight bollard and pit (kg)	490 (bollard) 250 (pit)
Oil quantity (l) (1)	3
Protection class	IP66
Overall dimensions	See Fig.2
Capacitor (2)	2 x 20µF - 400V
Burglar-proofing (J) (3)	656000



(1) check the oil level using the rod attached to the filler plug (Fig. 1 ref. ②) with the piston rod completely retracted and pressurised EFO system.

(2) The two thrust capacitors (20µF - 400v) can be preloaded inside the junction box (see Fig. 13).

(3) certified under ASTM F2656-07 CLASS M30-P1



1.3 DIMENSIONS

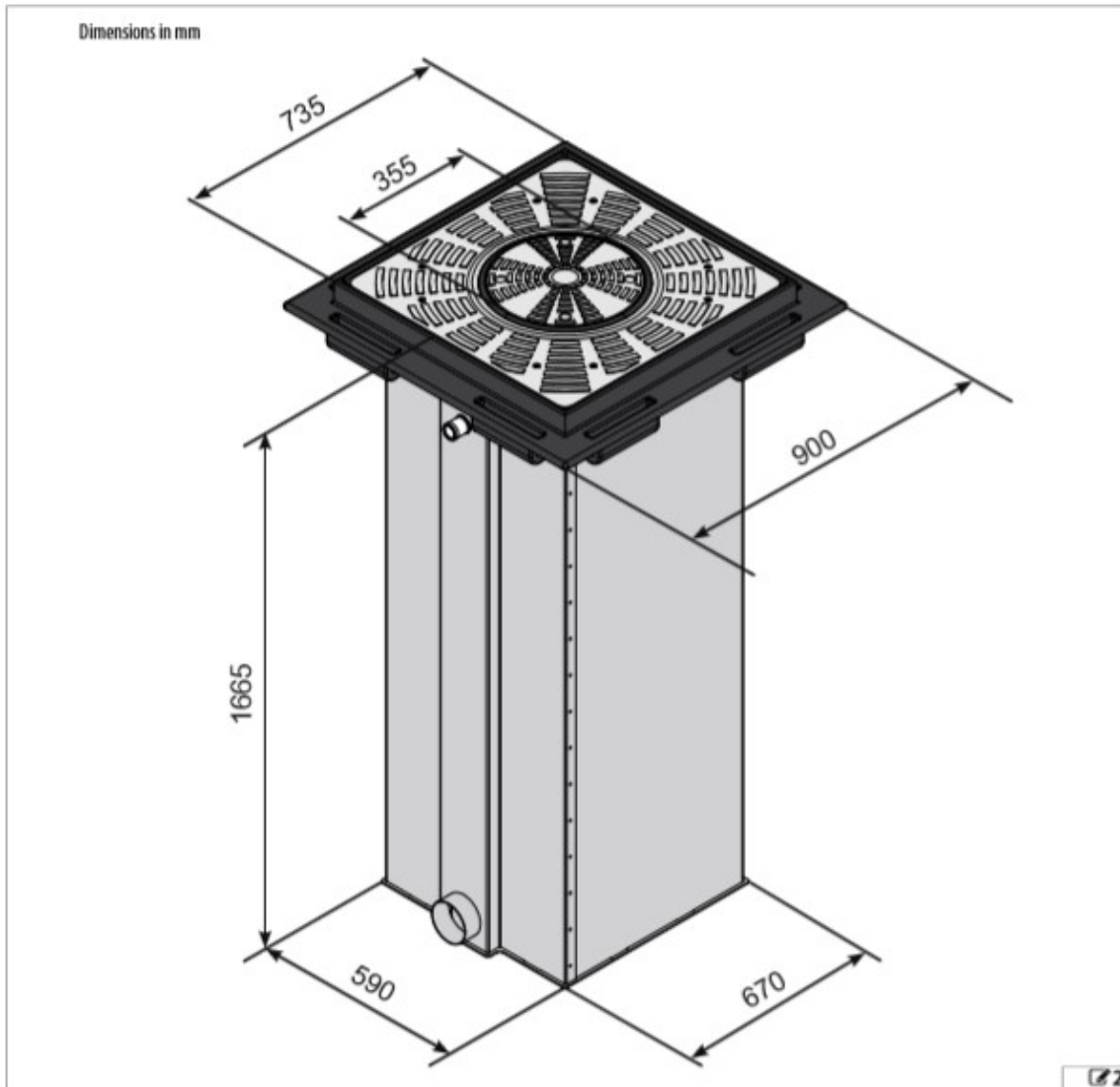

2.1 FACILITIES



For draining, use a \varnothing 100 flexible tube. Dig up to a depth of about 1.8 m

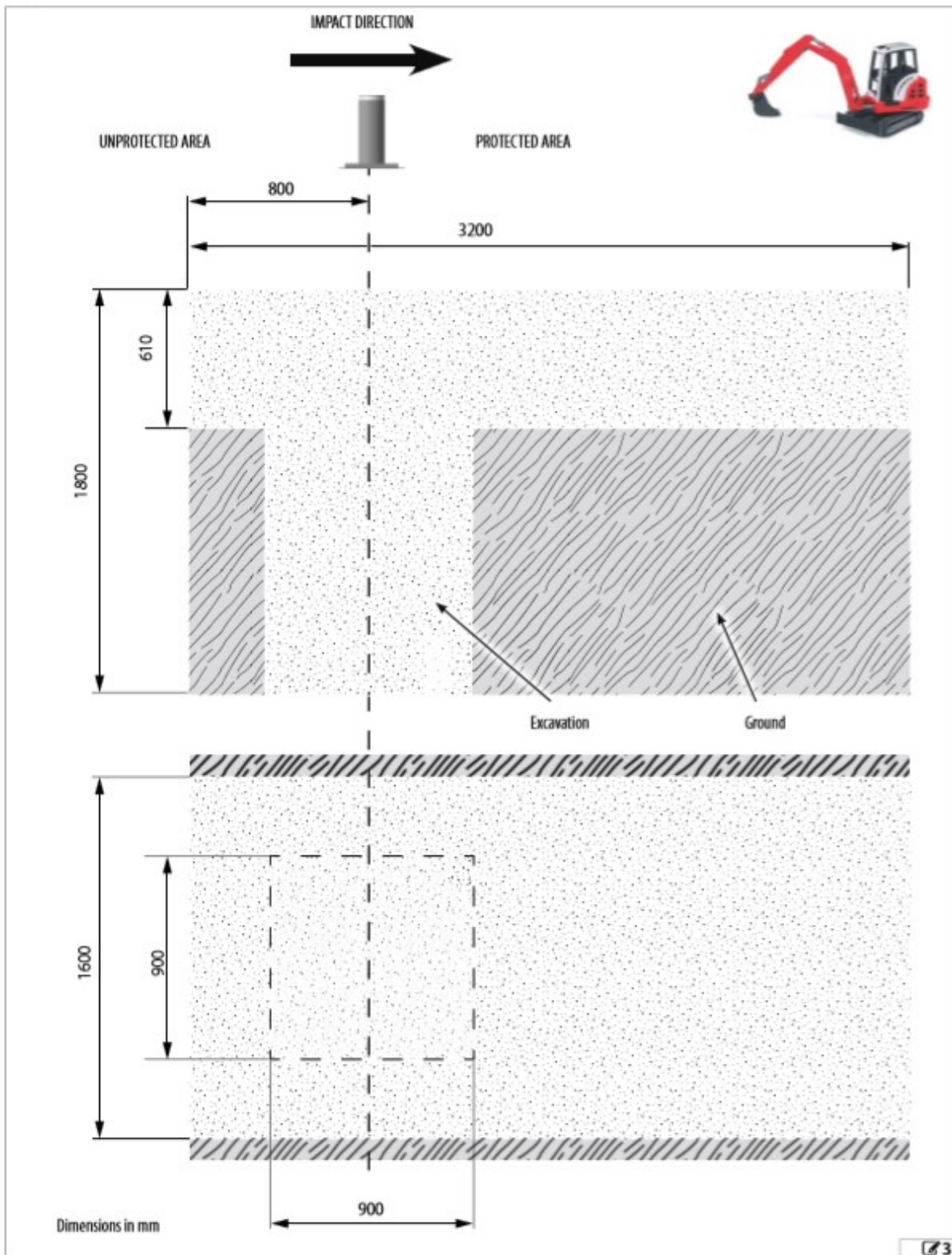

2.2 PREPARING THE FOUNDATION CAGE

Prepare the foundation cage (not supplied by us) as shown in the figure below using $\varnothing 12$ mm Iron rods CLASS B450C

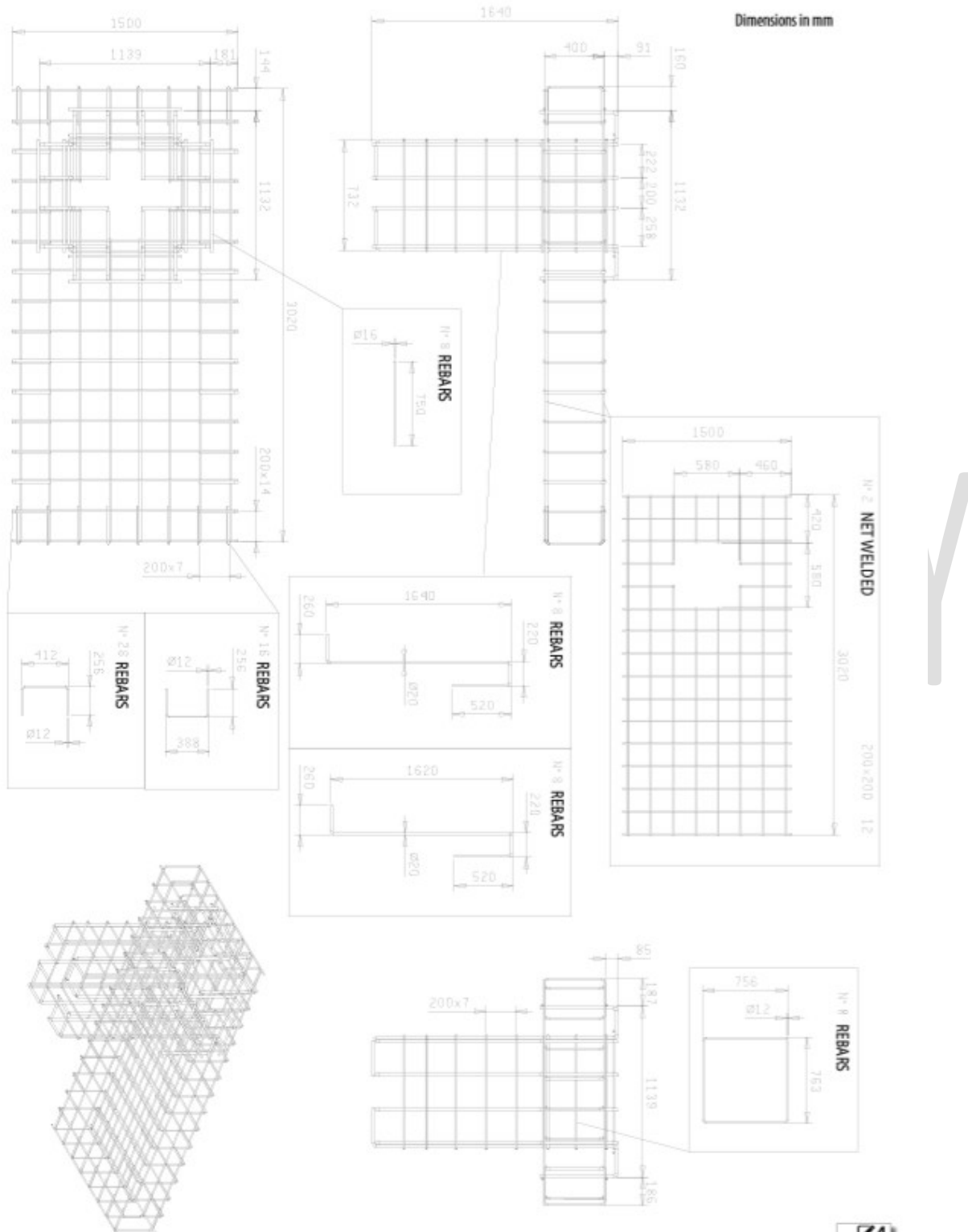

2.3 SECURING THE PIT

Once the foundation cage is completed, secure the counter-frame to the pit plate using the M10x25 screws, as shown in Fig. 5.

Then, place the pit in the cage as shown in Fig. 6, and carefully weld the 4 rods 760mm - Ø 16mm (ref. ① in Fig. 8) to the cage

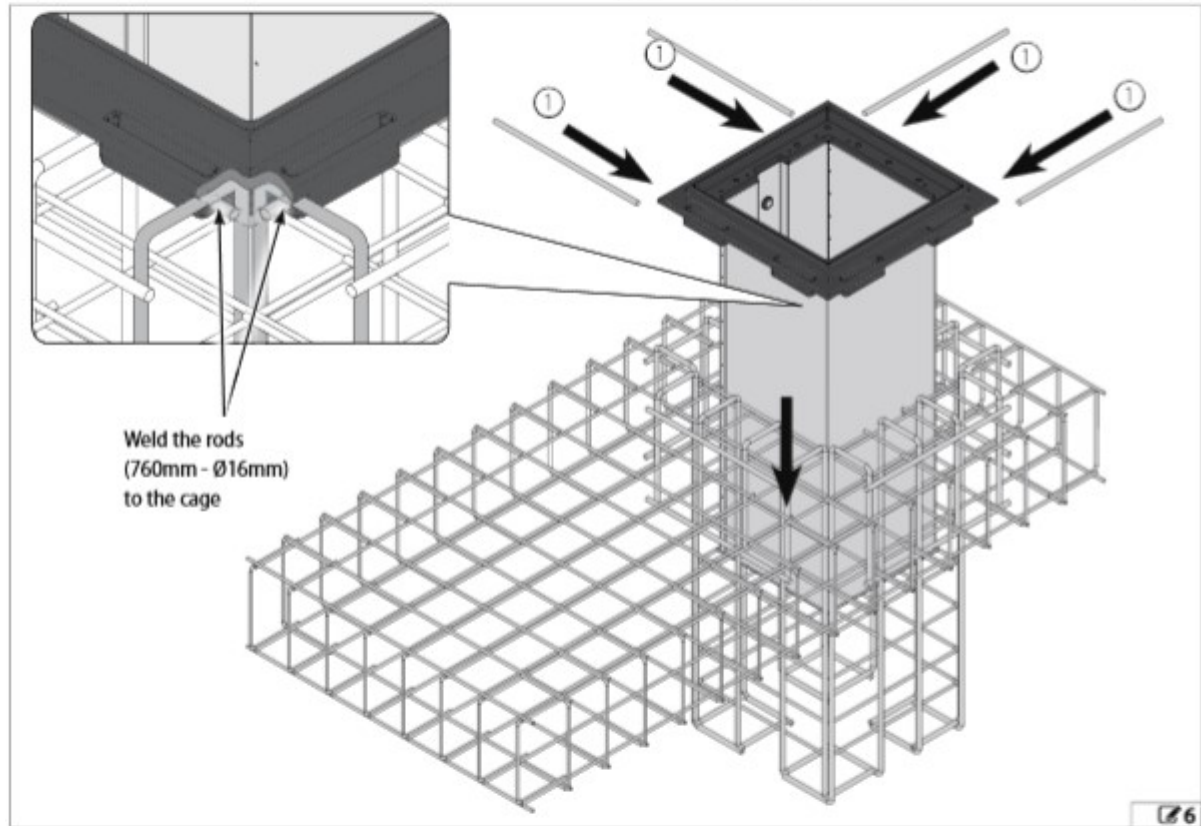
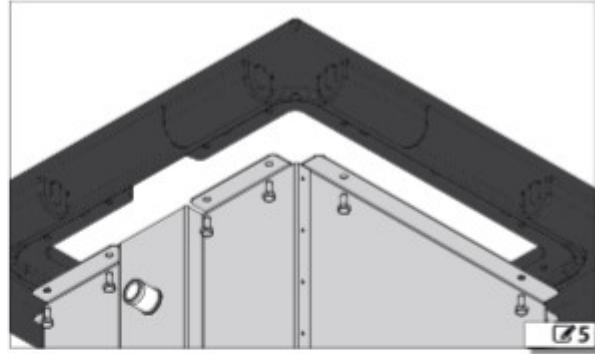

i Place the thus composed metal cage in the dug-out area, and ensure that it is plumb. The upper level of the counter-frame must be approximately 10 mm higher than the tread, as shown to the right (to limit entry of rainwater in the pit).

After installation of the pit, lay a flexible sheath, internal diameter 45mm, from the connection in the metallic pit to the drive control station (see Fig. 7).

Pour class C25/30 concrete all around the cage to secure it properly, up to approximately 10 cm from the tread area. Wait at least 7 days for the concrete to set correctly and finish the road surface using the same type of material.

Lay the pipelines, that are necessary for the connection between the control unit and any additional device, if any. Prepare the electrical connection and the earthing.

To connect the bollard to the control board, use a cable, type **FG70R-0,6/1kV-16G1,5**, having a max. length of 50 m.

N.B.: every pipe must be laid in compliance with the current rules.

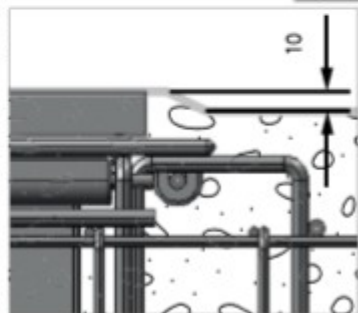

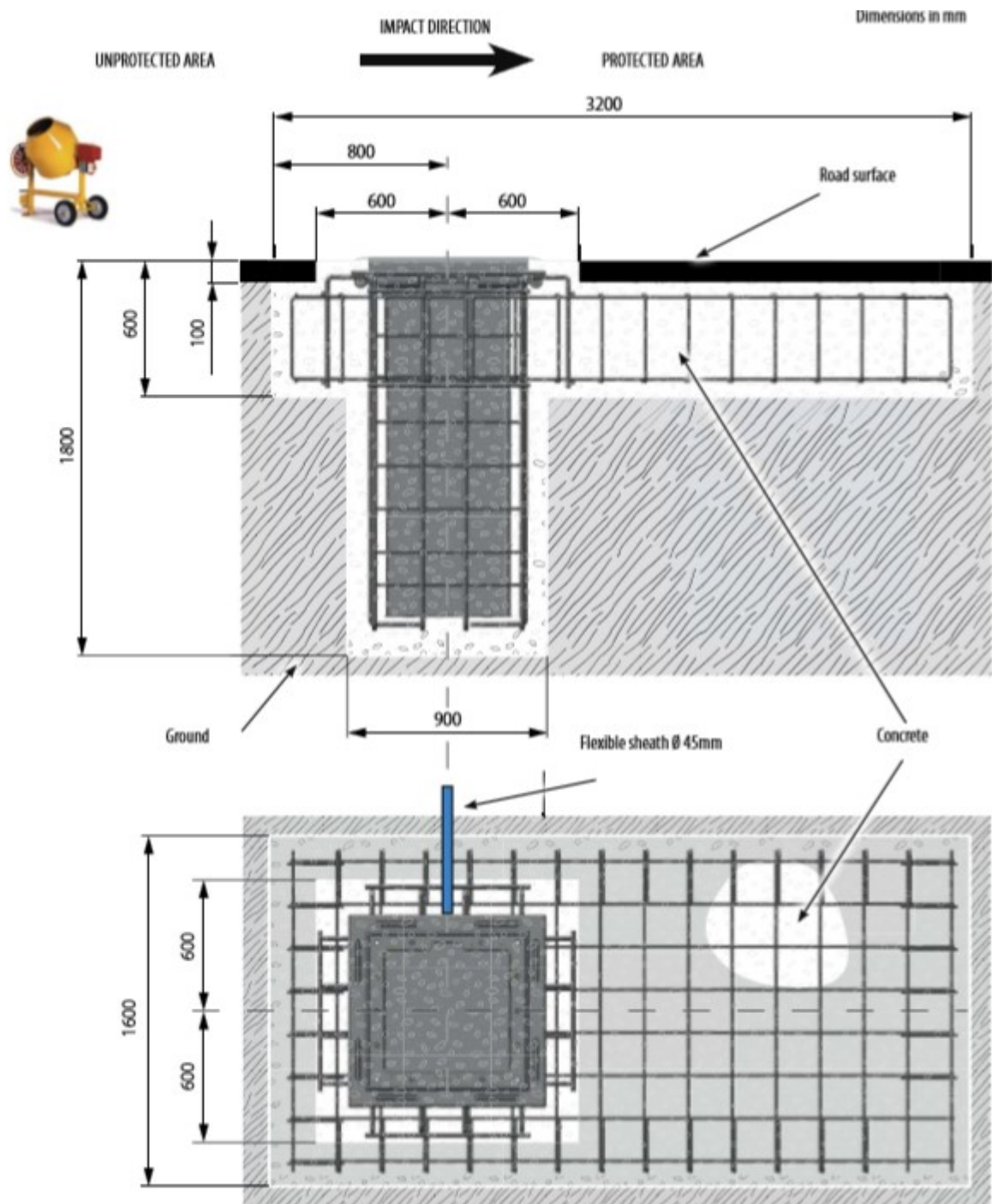

i The foundation concrete can be poured directly into the dug-out area.
Concrete specifications:

2.4 ELECTRIC WIRING

For the connection of the bollard to the control unit, use a multi-pole cable, type **FG70R-0,6/ kV- 16G 1.5 (16 cables of 1.5mm²)** with **max. length of 50 m**. This cable must be laid inside a sheath \varnothing 45mm, secured to the cable clamp in the bottom part of the frame (fig. 8 ref. ①) and must come out of the pit by 2.5 m.

Perform the electric wiring in the junction box on the bollard side, as shown in Fig. 13.



Any additional accessory (i.e. photocells, opening/closing push-buttons, etc.), that have to be connected to the control unit, must compulsorily have double insulation.

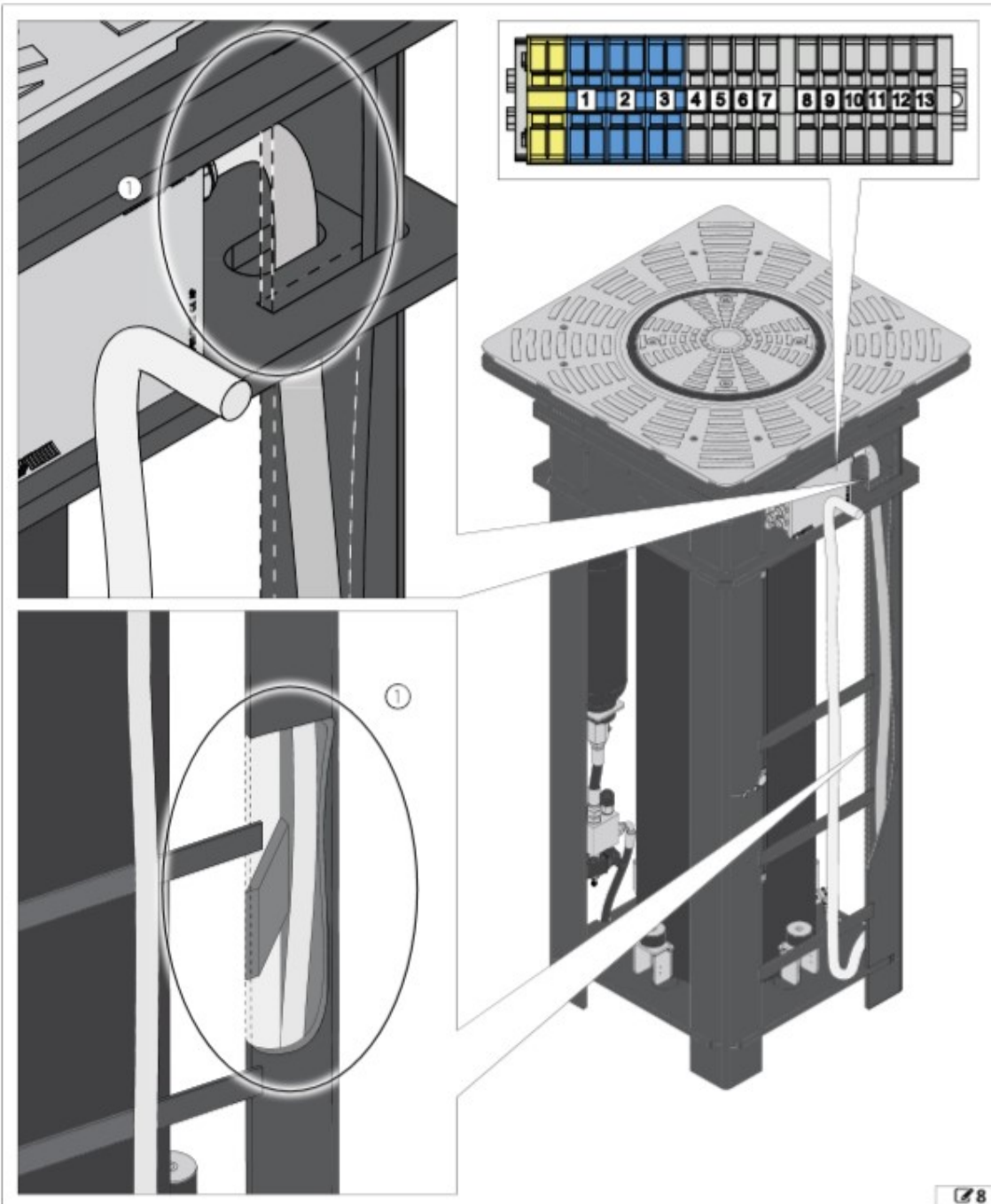

2.5 INSERTING THE BOLLARD IN THE PIT

To place the bollard in the previously prepared pit (wait at least 7 days for the cement to set), you must screw two eyebolts M20 on the top part, as shown in the figure below, using them as hooking points for the lifting operation with belts or chains.

- i** Before inserting the bollard in the pit, wire as described in the previous chapter and check its correct operation, also checking the correct intervention of the safety devices (see "JE275 ELECTRONIC EQUIPMENT" on page 11).

Lift and insert completely the bollard in the pit.

- i** During this phase ensure the cable is positioned correctly to prevent it from being crushed between the pit and the bollard frame.

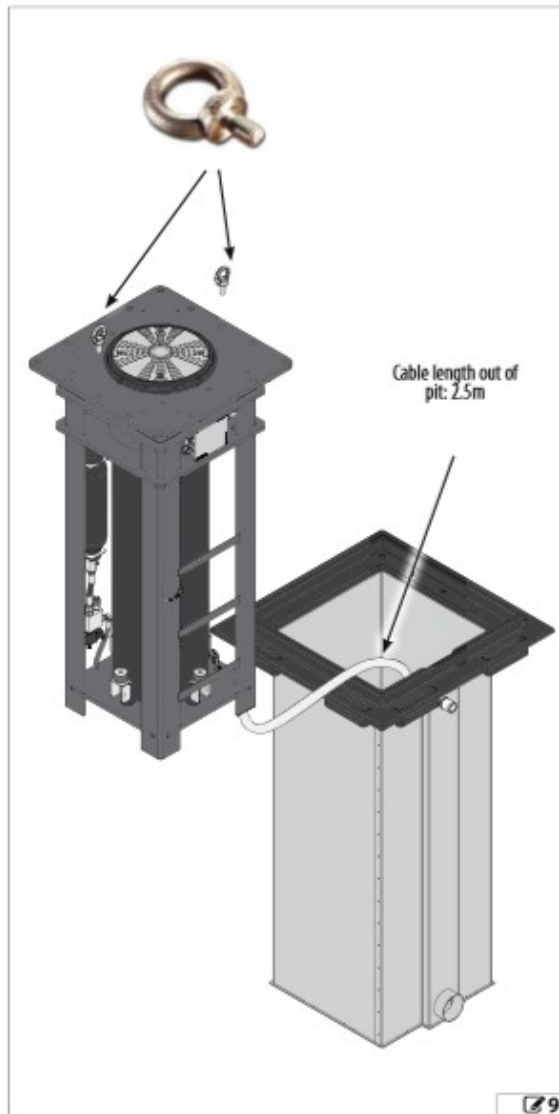

After completely inserting the bollard and resting it on the pit counter-frame, remove the two eyebolts and secure the bollard to the pit using the 15 provided cylindrical head screws with hexagon socket M20x45.

- i** **IMPORTANT:**
TIGHTEN THE 15 SCREWS USING **200Nm** TORQUE

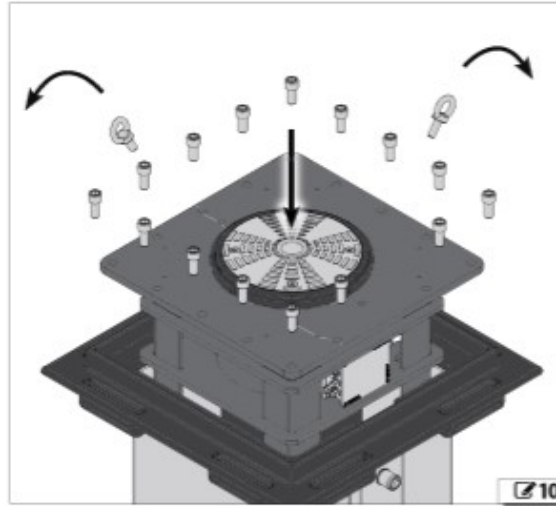

2.6 FASTENING THE TOP CROWN

After having secured the bollard, complete the installation positioning and securing the top crown with 8 cylindrical head screws with hexagon socket M8x30 INOX supplied standard

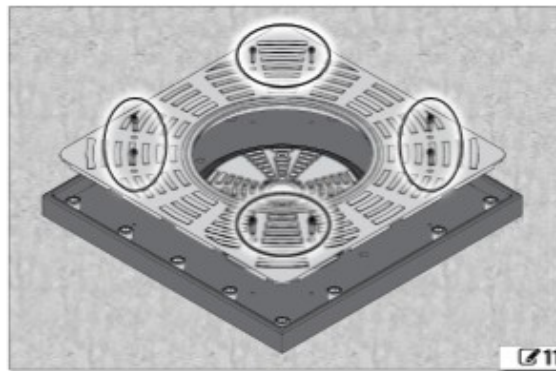

2.7 EFO (OPTIONAL)

The J355HA M30-P1 bollard can be equipped with an Emergency Fast Operation "EFO" that can be activated at any time to command immediate rising of the automation. The EFO system consists of a tank, a pressure switch and a control solenoid valve powered at 230 V ~. For connection of the solenoid valve (different depending on the N.O. / N.C. option used), refer to Fig. 13, terminals 4 and 5.

The N.O. solenoid valve allows activation of the EFO if commanded by the operator or in the event of a power failure, whilst the N.C. version only allows voluntary activation of the device.

2.8 MANUAL RELEASE (OPTIONAL)

To manually lower the bollard, use the release device following the instructions below.

1. Loosen and remove the 8 cylindrical head screws with hexagon socket M8x30 securing the upper crown (Fig. 12 ref. ①).
2. Remove the upper crown (Fig. 12 ref. ②)
3. Insert the key supplied in the hole and rotate it one turn anticlockwise to lower the bollard (Fig. 12 ref. ③).

2.9 AUTOMATIC OPERATION

To restore the automatic operation:

1. Insert the key in the hole and rotate clockwise all the way down.
2. Refit the upper crown.
3. Tighten the 8 cylindrical head screws with hexagon socket M8x30 securing the upper crown.

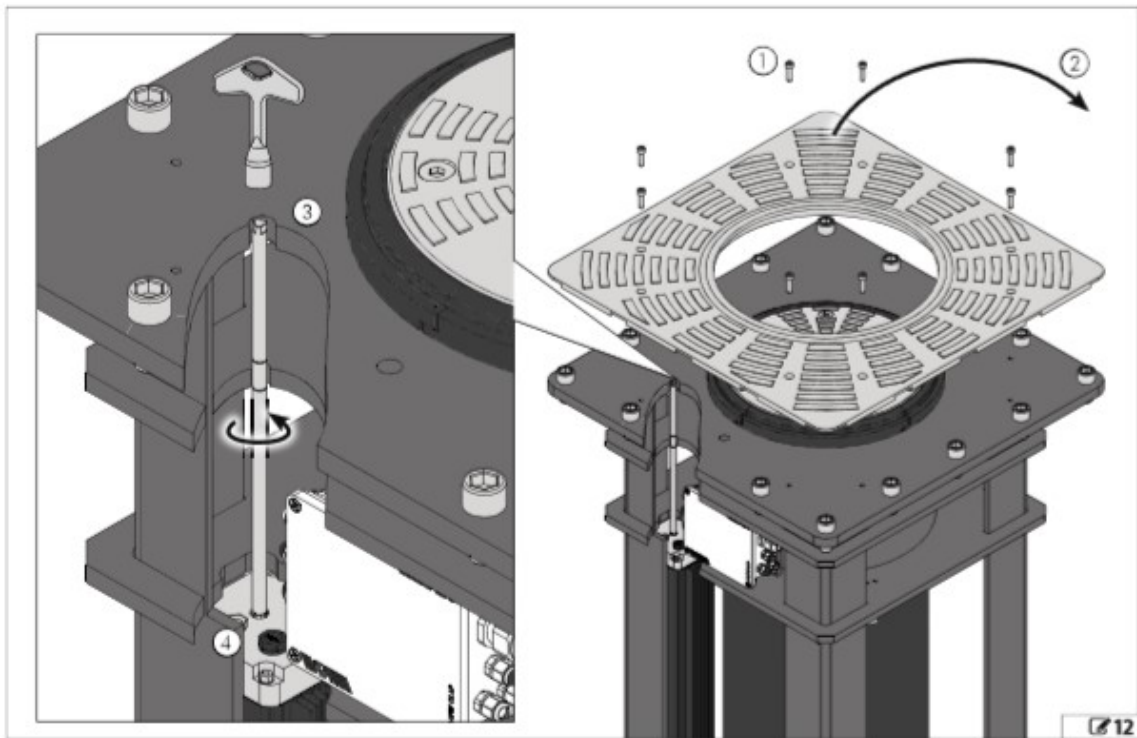

2.10 MAINTENANCE

The standard routine maintenance sequence is as follows:

1. Clean the pit using vacuum for deposited materials
2. Clean the drained water at the bottom of the pit
3. Check (and, if necessary, replace) the lower stop gaskets
4. Check and, if necessary, repair any oil leaks affecting the drive piston
5. Check that all the bollard screws are correctly tightened
6. Clean the drive cylinder and, if necessary, touch up the paintwork
7. Check the hydraulic unit; top up the oil, if necessary
8. Verify that the EFO system works correctly

3. JE275 CONTROL UNIT



Always cut the power supply before performing any intervention on the control unit (connections, maintenance).
 Install a differential thermal-magnetic switch with suitable threshold (0.03A) upstream of the system.
 Connect the earth cable to the relevant terminal on the connector J9 of the unit (see figure below).
 Ensure that the grid disconnect switch has a lock key, unless it is installed in view of the operator/maintenance technician.



The equipment must be laid at a height ranging between 0.4 m and 2.0 m.

3.1 ELECTRICAL CONNECTIONS

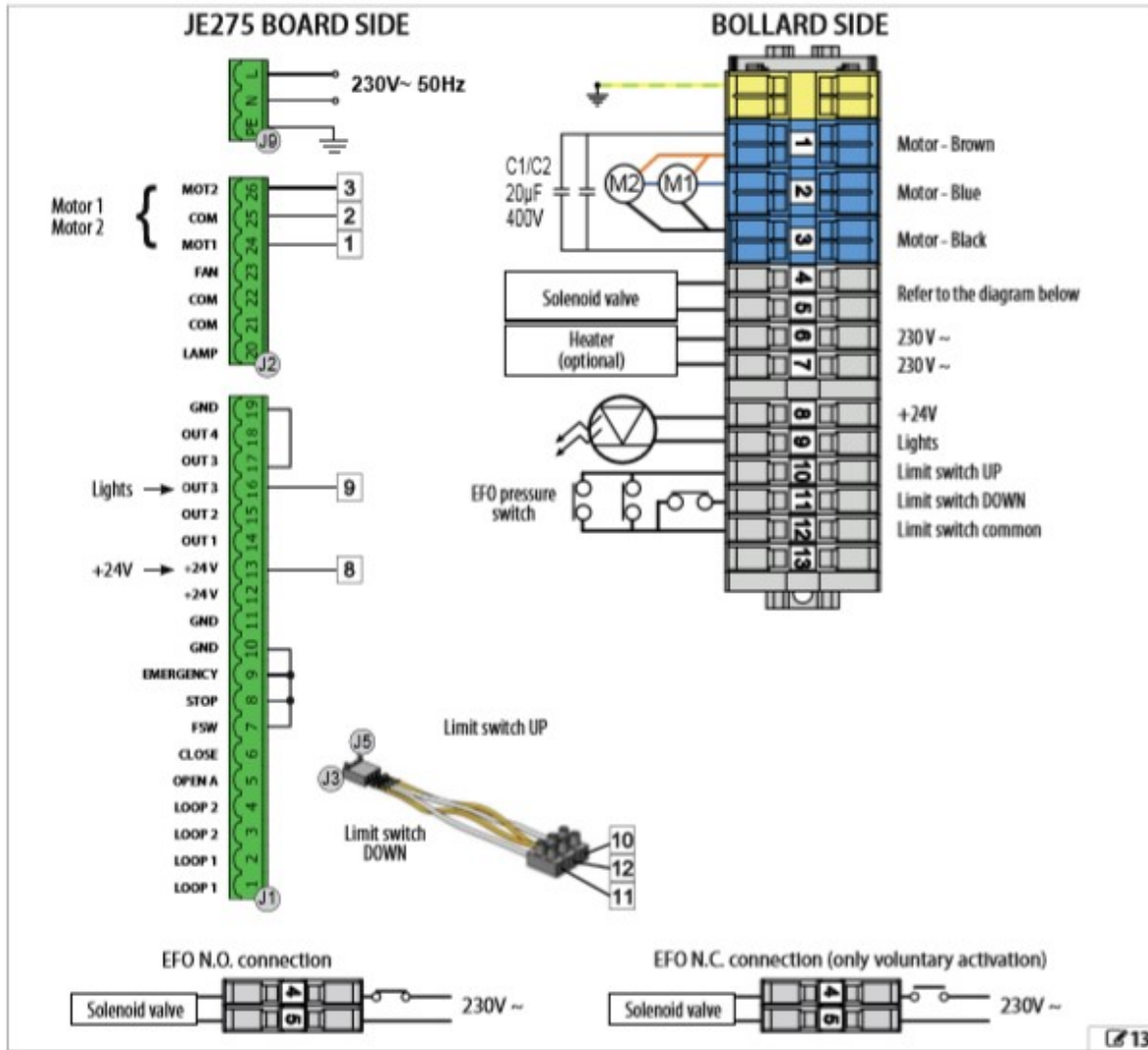

3.2 PRE-SETTING SELECTION

After having connected the board and after having supplied it with power according to the previous paragraph, you must select the work pre-setting for the bollard J355 M30-P1 following the operations below:

1. Enter the 1st level programming, holding down key F on the board. The initials dF will appear on the display
2. Release the F key and select 06 with the key +
3. Simultaneously press keys F and - to exit programming and save the changes performed.

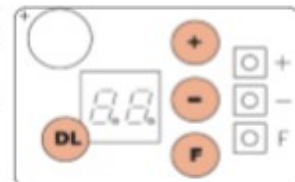

For any further information on the unit programming, please refer to the relevant instructions.

3. JE275 CONTROL UNIT



Always cut the power supply before performing any intervention on the control unit (connections, maintenance).
 Install a differential thermal-magnetic switch with suitable threshold (0.03A) upstream of the system.
 Connect the earth cable to the relevant terminal on the connector J9 of the unit (see figure below).
 Ensure that the grid disconnect switch has a lock key, unless it is installed in view of the operator/maintenance technician.



The equipment must be laid at a height ranging between 0.4 m and 2.0 m.

3.1 ELECTRICAL CONNECTIONS

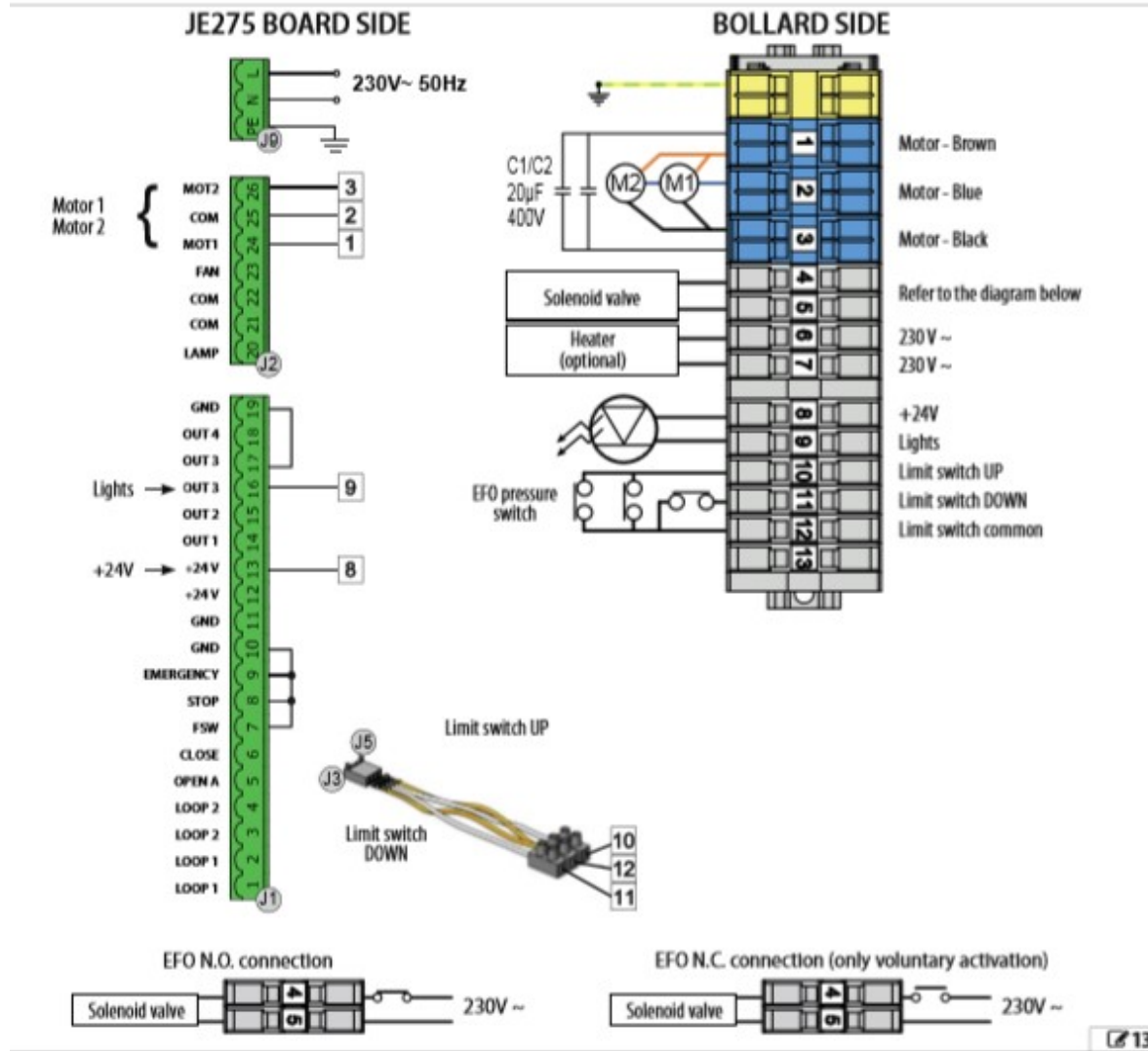

3.2 PRE-SETTING SELECTION

After having connected the board and after having supplied it with power according to the previous paragraph, you must select the work pre-setting for the bollard J355 M30-P1 following the operations below:

1. Enter the 1st level programming, holding down key F on the board. The initials dF will appear on the display
2. Release the F key and select 06 with the key +
3. Simultaneously press keys F and - to exit programming and save the changes performed.

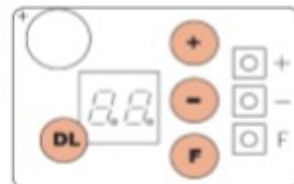

For any further information on the unit programming, please refer to the relevant instructions.

3.3 CONNECTION OF SEVERAL BOLLARDS (MASTER/SLAVE)

Several bollards can be commanded simultaneously by connecting them together with the corresponding JE275 equipment in MASTER-SLAVE configuration. Follow the indications below for correct wiring and operation.

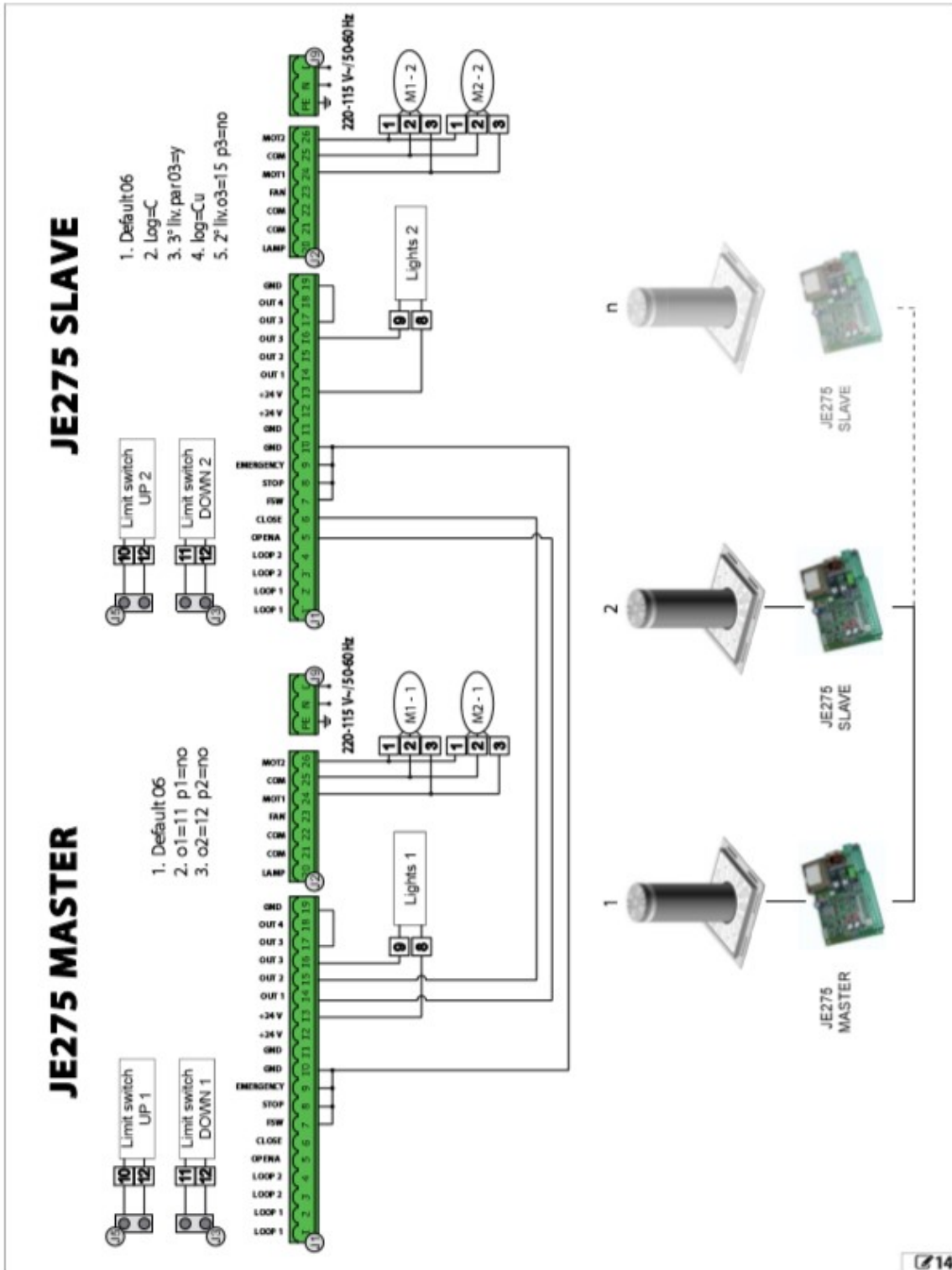

3.4 TROUBLESHOOTING

The indications below will help you locate and solve particular conditions.

CONDITION	ADVICE
The bollard does not rise, it remains down.	Make sure you have selected the default no. 6 on the JE275 board Check if the wiring of the solenoid valve was performed correctly, see par. 9 Check the electrical wiring of the motor
The bollard remains up in closed position.	Make sure nothing between the cylinder and the sliding bush prevents the bollard movement Check the electrical wiring of the motor
The LED flashing lamp does not operate	Make sure you have selected the default no. 6 on the JE275 board Check if the power connector under the head was fitted correctly.

4. PERFORMING MAINTENANCE ON THE EFO SYSTEM



The EFO system tank is always under pressure. Before carrying out any maintenance operation, to avoid potentially dangerous situations, the circuit must be discharged before any other operation.

The bollard is rapidly closed when the EFO is activated. Clear the relative area from objects and people in order to prevent dangerous situations

To discharge the EFO, activate the system by opening the contact between terminals 7 and 8 of the terminal board (EFO N.O.) or supplying voltage to the solenoid valve via the same terminals (EFO N.C.), then **slowly** unscrew the screws in figure 15, ref. ①

